



Product introduction

NBW-W-PPT The SMD temperature sensor (transmitter) adopts high-precision thermistor as the sensing component, which has the characteristics of high measurement accuracy and good stability. The signal transmitter adopts advanced circuit integration module, which can convert temperature into corresponding voltage or current signal according to different needs of users. The instrument is small in size, easy to install and portable, and has reliable performance; it adopts a proprietary line, which has good linearity, strong load capacity, long transmission distance and strong anti-interference ability. It can be widely used in temperature measurement in the fields of meteorology, ocean, environment, airport, port, laboratory, industry, agriculture and transportation.

Technical Parameter

Range: -50~100°C

-20~50°C

Accuracy: ±0.5°C

Power supply mode:

DC 5V

DC 12V

DC 24V

Other

Output form:

Current: 4~20mA

Voltage: 0~2.5V

Voltage: 0~5V

RS485

Other

Instrument cable length:

Standard: 5 meters

Other

Load resistance: Voltage type: $RL \geq 1K$

Current type: $RL \leq 250\Omega$

Working temperature: -50°C ~ 100°C

Relative humidity: 0~100%RH

Product weight: Probe 125 g

Product power consumption: 0.15W

Calculation formula

Voltage type (0~5V):

$$T = V / 5 \times 70 - 20$$

(T is the measured temperature value (°C), V is the output voltage (V), this formula corresponds to the measurement range -20 to 50°C)

$$T = V / 5 \times 150 - 50$$

(T is the measured temperature value (°C), V is the output voltage (V), this formula corresponds to the measurement range -50 to 100°C)

Current type (4~20mA)

$$T = (I-4) / 16 \times 70 - 20$$

(T is the measured temperature value (°C), I is the output current (mA), this formula corresponds to the measurement range -20 to 50°C)

$$T = (I-4) / 16 \times 150 - 50$$

(T is the measured temperature value (°C), I is the output current (mA), this formula corresponds to the measurement range -50~100°C)

Note: The calculation formulas corresponding to different signal outputs and different measurement ranges need to be recalculated!

Connection method

(1) If equipped with the collector produced by our company, directly connect the sensor to the corresponding interface on the collector using the sensor cable.

(2) The transmitter is purchased separately, and the matching line sequence of the transmitter is as follows:

Line	output signal
------	---------------

color	Voltage	Current	communication
Red	+	+	+
Black (Green)	-	-	-
Yellow	Voltage signal	Current signal	A
Blue			B

(3) There are two output wiring methods for sensor voltage and current:

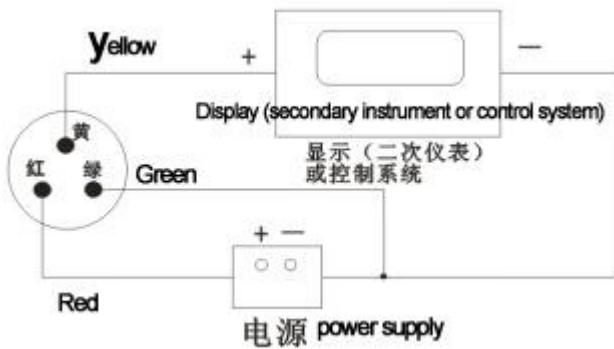

(Wiring diagram of voltage output mode)

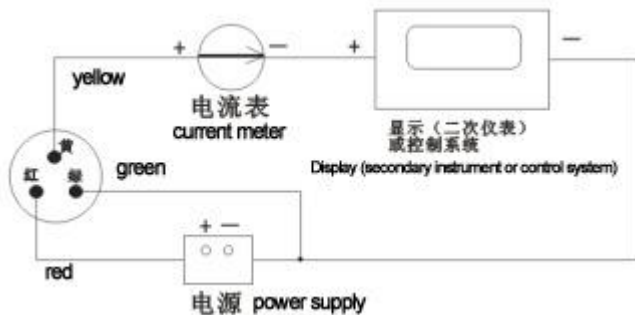

(Wiring diagram of current output mode)

MODBUS-RTU Communication protocol

1. Serial format

Data bits 8 bits

Stop bit 1 or 2 bits

Check Digit None

Baud rate 9600 The interval between two communications is at least 1000ms

2. Communication format

[1] Write device address

Send: 00 10 Address CRC (5 bytes)

Returns: 00 10 CRC (4 bytes)

Instructions: 1. The address bit of the read/write address command must be 00.

2. Address is 1 byte, the range is 0-255.

For example: send 00 10 01 BD C0

return 00 10 00 7C

[2] Read device address

Send: 00 20 CRC (4 bytes)

Returns: 00 20 Address CRC (5 bytes)

Description: Address is 1 byte, the range is 0-255

For example: send 00 20 00 68

Return 00 20 01 A9 C0

[3] Read real-time data

Send: Address 03 00 00 00 01 XX XX

Description: As shown in the figure below:

Code	Functional Definition	Remark
Address	Station number (address)	
03	Function code	
00 00	Start address	
00 01	Read points	
XX XX	CRC Check code, low front and high back	

Return: Address 03 02 XX XX XX XX

Description:

CODE	Functional Definition	Remark
Address	Station number (address)	
03	Function code	
02	Read unit bytes	
XX XX	Date (low front and high back)	Multiply decimal by 0.1
XX XX	CRC Check code	

For example: send 01 03 00 00 00 01 84 0A

Return 01 03 02 00 B4 B8 33

Note: 00 B4 converted to hexadecimal is 180, after data analysis, with one decimal point, it needs to be divided by ten, the actual temperature value is 18.0 °C

Steps to calculate CRC code:

1. The preset 16-bit register is hexadecimal FFFF (that is, all 1s). Call this register the CRC register;
2. XOR the first 8-bit data with the lower bits of the 16-bit CRC register, and place the result in the CRC register;
3. Shift the contents of the register one bit to the right (toward the lower bit), fill the highest bit with 0, and check the shifted out bit after the right shift;
4. If the shift out bit is 0: repeat step 3 (shift right one bit again)

If the shift-out bit is 1: XOR the CRC register with the polynomial A001 (1010 0000 0000 0001);

5. Repeat steps 3 and 4 until the right shift is performed 8 times, so that the entire 8-bit data is processed;
6. Repeat steps 2 to 5 to process the next 8-bit data;
7. The final CRC register is the CRC code;
8. When the CRC result is put into the information frame, the high and low bits are exchanged, and the low bits are first.

RS485 Circuit

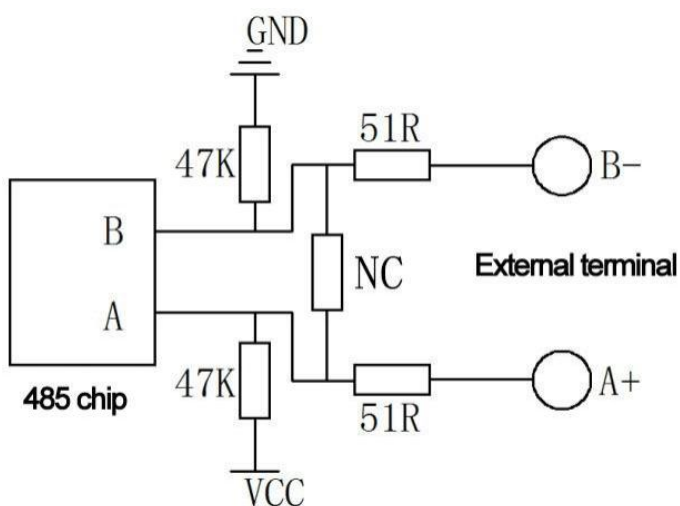

Instruction manual

1. In the center of the back of the solar panel, use the thermally conductive silica gel supplied with the package to spread along the direction of the solar panel bracket to an area with a size of about

- 22*12mm;
2. After the application is completed, immediately stick the patch temperature sensor in the direction of application, and fix it for about 5 to 10 minutes;
3. When the sensor is completely fixed on the back of the solar panel, first follow the direction of the solar panel wiring, fix the patch temperature sensor wire on the solar bracket, and then perform the normal wiring;
4. The user can fix the SMD temperature sensor according to the actual use environment and refer to the above method

Trouble clearing

1. During analog output, the indicator indicates that the value is 0 or not within the range. The collector may not be able to obtain information correctly due to wiring problems. Please check whether the wiring is correct and firm, and whether the power supply voltage is normal;
2. If it is not for the above reasons, please contact the manufacturer.

Notice

1. Please check whether the packaging is in good condition, and check whether the product model is consistent with the selection;
2. Do not connect with live power. After the wiring is completed and checked, the power can be turned on;
3. The length of the sensor line will affect the output signal of the product. Do not arbitrarily change the components or wires that have been soldered when the product leaves the factory. If you need to change it, please contact the manufacturer;
4. The sensor is a precision device, please do not disassemble it by yourself when using it to avoid damage to the product;
5. Please keep the verification certificate and qualification certificate, and return it together with the product during maintenance.

Selection table

No.	Power supply	output signal	explanation
NBL-W-PPT-			SMD temperature sensor (transmitter)
	12V-24V		12V-24V Power supply
		0	no transmission
		V	0-2.5V
		A1	4-20mA
		W2	RS485
For example: NBL-W-PPT-12V-A1: SMD temperature sensor (transmitter) 12V power supply, 4-20mA output			

Schedule

Standard temperature sensor, corresponding relationship between resistance value and temperature.

(°C)	(kΩ)	(°C)	(kΩ)
-50	329.500	-13	48.680
-49	310.900	-12	46.500
-48	293.500	-11	44.430
-47	277.200	-10	42.470
-46	262.000	-9	40.570
-45	247.700	-8	38.770
-44	234.300	-7	37.060
-43	221.700	-6	35.440
-42	209.900	-5	33.900
-41	198.900	-4	32.440
-40	188.500	-3	31.050
-39	178.500	-2	29.730
-38	169.000	-1	28.480
-37	160.200	0	27.280
-36	151.900	1	26.130
-35	144.100	2	25.030
-34	136.700	3	23.990
-33	129.800	4	23.000
-32	123.300	5	22.050
-31	117.100	6	21.150
-30	111.300	7	20.300
-29	105.700	8	19.480
-28	100.500	9	18.700
-27	95.520	10	17.960
-26	90.840	11	17.240
-25	86.430	12	16.560
-24	82.260	13	15.900
-23	78.330	14	15.280
-22	74.610	15	14.690
-21	71.100	16	14.120
-20	67.770	17	13.580
-19	64.570	18	13.060
-18	61.540	19	12.560
-17	58.680	20	12.090
-16	55.970	21	11.630
-15	53.410	22	11.200
-14	50.980	23	10.780

(°C)	(kΩ)	(°C)	(kΩ)
24	10.380	63	2.751
25	10.000	64	2.668
26	9.632	65	2.588
27	9.281	66	2.511
28	8.944	67	2.436
29	8.622	68	2.364
30	8.313	69	2.295
31	8.014	70	2.228
32	7.728	71	2.163
33	7.454	72	2.100
34	7.192	73	2.039
35	6.940	74	1.980
36	6.698	75	1.924
37	6.467	76	1.869
38	6.245	77	1.816
39	6.032	78	1.765
40	5.827	79	1.716
41	5.629	80	1.668
42	5.439	81	1.621
43	5.255	82	1.577
44	5.080	83	1.533
45	4.911	84	1.491
46	4.749	85	1.451
47	4.593	86	1.411
48	4.443	87	1.373
49	4.299	88	1.336
50	4.160	89	1.300
51	4.026	90	1.266
52	3.896	91	1.323
53	3.711	92	1.200
54	3.651	93	1.168
55	3.536	94	1.137
56	3.425	95	1.108
57	3.318	96	1.079
58	3.215	97	1.051
59	3.116	98	1.024
60	3.020	99	0.9984
61	2.927	100	0.9731
62	2.838		