



Product introduction

The TBQ total radiation sensor adopts the principle of thermoelectric induction and is used in conjunction with various radiation recorders or radiation ammeters to accurately measure the sun's TBQ total radiation, reflected radiation, scattered radiation, infrared radiation, visible light, ultraviolet radiation, long-wave radiation, etc.

The core sensing element of the watch adopts a wire-wound electroplating multi-contact thermopile, and its surface is coated with a black coating with high absorption rate. The hot junction is on the sensing surface, while the cold junction is located in the body, and the cold and hot junctions generate a thermoelectric potential. In the linear range, the output signal is proportional to the solar irradiance. The double-layer glass cover is to reduce the influence of air convection on the pyranometer, and the inner cover is designed to cut off the infrared radiation of the outer cover itself.

Use

The meter is used to measure the total solar TBQ radiation in the spectral range of 0.3-3 μ m, and it can also be used to measure the solar radiation incident on the inclined plane. If the sensing surface is facing down, the reflected radiation can be measured, and the shading ring can be used to measure the scattered radiation. Therefore, it can be widely used in solar energy utilization, meteorology, agriculture, aging of

building materials and air pollution to measure solar radiation energy.

Technical Parameters

Sensitivity: 7~14 μ V/w.m-2

Spectral range: 0.3-3 μ m

Measuring range: 0~2000W/m2

Power supply mode: DC 5V

DC 12V

DC 24V

Other

Output form: Current: 4~20mA

Voltage: 0~2.5V

Voltage: 0~5V

Voltage: 0~20mV

RS485

Other

Instrument cable length: Standard: 2.5 meters

Other

Response time: \leq 35 seconds (99%)

Internal resistance: about 350 Ω

Annual stability: \leq \pm 2%

Cosine response: \leq 7% (when the sun altitude angle is 10 $^\circ$)

Azimuth response error: \leq 5% (when the sun elevation angle is 10 $^\circ$)

Temperature characteristics: \pm 2% (-10 $^\circ$ C ~ +40 $^\circ$ C)

Working environment temperature: -40 $^\circ$ C ~ +50 $^\circ$ C

Nonlinearity: \leq 2%

Weight: 2.5kg

Calculation formula

Voltage type (0~20mV):

$F=(V/\text{sensitivity coefficient})\times 1000$

F: Radiation value, unit W/m2, V: output voltage, unit mV, sensitivity coefficient Check TBQ test report

Voltage type (0~5V):

$F=(V/5)\times 2000$

F: radiation value, unit W/m2, V: output voltage, unit V, radiation test range 0~2000W/m2

Current type (4~20mA):

$F=(I-4)/16\times 2000$

NBL-W-HPRS/Total radiation sensor V3.0
Changsha Zoko-Link Technology Co., Ltd.

F: radiation value, unit W/m², I: output current, unit mA, radiation test range 0~2000W/m²

Connection method

- (1) If equipped with the collector produced by our company, directly connect the sensor to the corresponding interface on the collector using the sensor cable.
- (2) If the transmitter is purchased separately, the corresponding line sequences are:

Line color	output signal		
	Voltage	Current	Communications
Red	+	+	+
Black (Green)	-	-	-
Yellow	Voltage signal	Current Signal	A+/TX
Blue			B-/RX

External structure



□ TBQ Total Radiation Dimensions

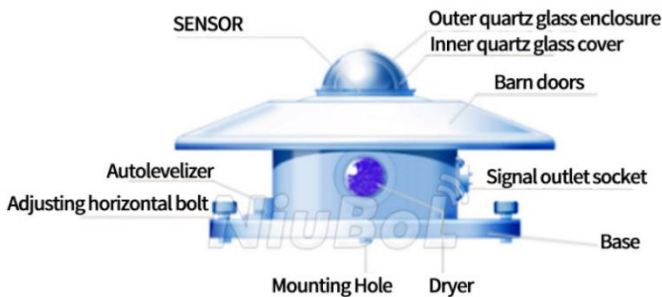

□ TBQ Total Radiation Functional diagram

Dimensions

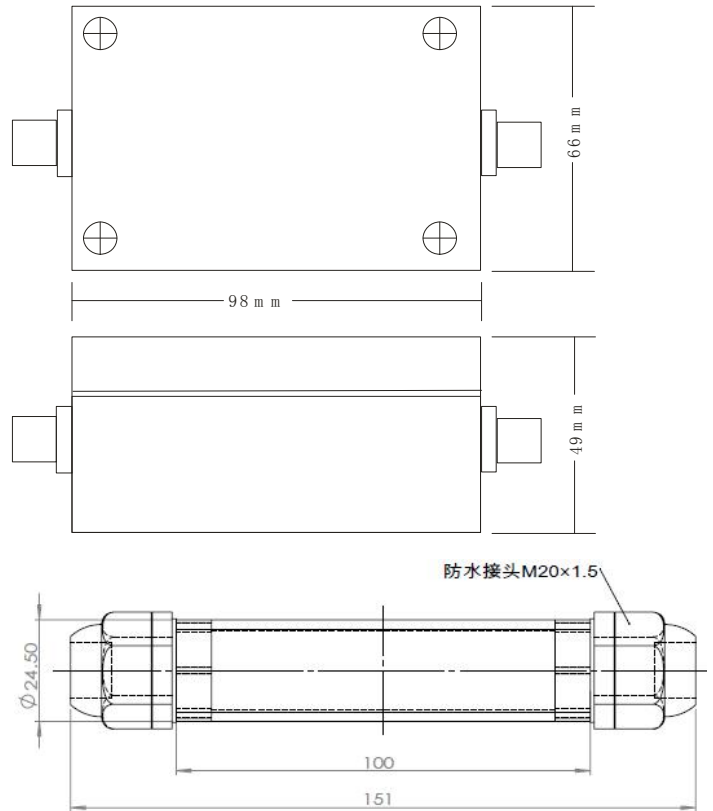

installation and use

The sensor should be installed in an open area without any obstacles above the sensing surface. Then, align the pyranometer cable plug to the north, adjust the horizontal position, fix it firmly, and then connect the TBQ pyranometer output cable with the acquisition device to observe. It's a good idea to have the cables securely fastened to the mount to reduce breaks or intermittent interruptions on windy days.

Wiring Instructions:

Name	Line Color	Description of output	Corresponding plug pins
TBQ total radiation sensor	Red	+	1 pin of the four-core plug
	Black (Green)	-	2 pins of the four-pin plug

MODBUS-RTU Communication Protocol

NBL-W-HPRS/Total radiation sensor V3.0
Changsha Zoko-Link Technology Co., Ltd.

I Serial port format
 Data bits 8 bits
 Stop bit 1 or 2 bits
 Check Digit None
 Baud rate 9600 The interval between two communications is at least 1000ms

II Communication format

[1] Write device address
 Send: 00 10 Address CRC (5 bytes)
 Returns: 00 10 CRC (4 bytes)
 Instructions: 1. The address bit of the read/write address command must be 00.
 2. Address is 1 byte, the range is 0-255.
 For example: send 00 10 01 BD C0
 return 00 10 00 7C

[2] Read device address
 Send: 00 20 CRC (4 bytes)
 Returns: 00 20 Address CRC (5 bytes)
 Description: Address is 1 byte, the range is 0-255
 For example: send 00 20 00 68
 Return 00 20 01 A9 C0

[3] Read real-time data
 Send: Address 03 00 00 00 01 XX XX
 Description: As shown in the figure below:

Code	Functional Definition	Remark
Address	Station number (address)	
03	Function code	
00 00	Start address	
00 01	Read points	
XX XX	CRC Check code, low front and high back	

Return: Address 03 02 XX XX XX XX
 illustrate:

Code	Functional Definition	Remark
Address	Station number (address)	
03	Function code	

02	Read unit bytes	
XX XX	Data (front high and back low)	hex
XX XX	CRC Check code	

Steps to calculate CRC code:

1. The preset 16-bit register is hexadecimal FFFF (that is, all 1s). Call this register the CRC register;
2. XOR the first 8-bit data with the lower bits of the 16-bit CRC register, and place the result in the CRC register;
3. Shift the contents of the register one bit to the right (toward the lower bit), fill the highest bit with 0, and check the lowest bit;
4. If the lowest bit is 0: repeat step 3 (shift again)
 If the lowest bit is 1: XOR the CRC register with the polynomial A001 (1010 0000 0000 0001);
5. Repeat steps 3 and 4 until the right shift is performed 8 times, so that the entire 8-bit data is processed;
6. Repeat steps 2 to 5 to process the next 8-bit data;
7. The final CRC register is the CRC code;
8. When the CRC result is put into the information frame, the high and low bits are exchanged, and the low bits are first.

RS485 circuit

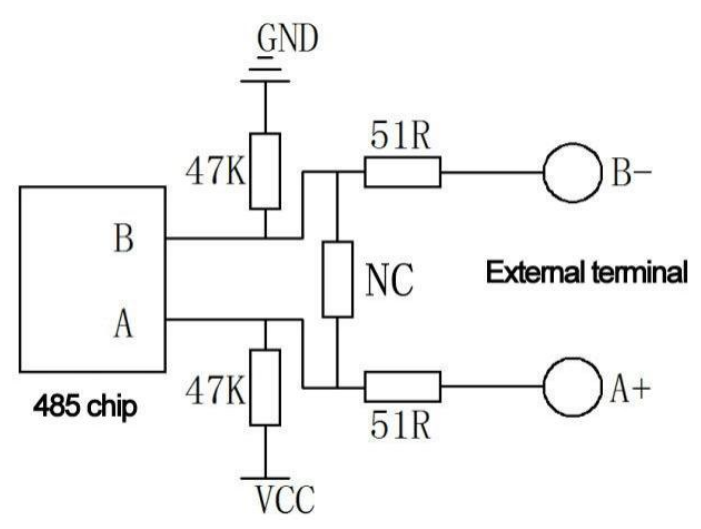

Instruction manual

Wire the sensor according to the instructions in the

NBL-W-HPRS/Total radiation sensor V3.0
Changsha Zoko-Link Technology Co., Ltd.

wiring method, then place it at the position where the radiation is to be measured, turn on the power supply and the switch of the collector, and the radiation value at the measurement point can be obtained.

Notice

1. Please check whether the packaging is in good condition, and check whether the product model is consistent with the selection;
2. Do not connect with live power. After the wiring is completed and checked, the power can be turned on;
3. The length of the sensor line will affect the output signal of the product. Do not arbitrarily change the components or wires that have been soldered when the product leaves the factory. If you need to change it, please contact the manufacturer;
4. The sensor is a precision device, please do not disassemble it by yourself, or touch the surface of the sensor with sharp objects or corrosive liquid, so as not to damage the product;
5. Please keep the verification certificate and qualification certificate, and return it together with the product during maintenance.

Trouble clearing

1. During the analog output, the displayed value is obviously too large/small. Please check whether there is dirt or debris on the sensor port; if so, wipe it off with a clean rag;
2. During analog output, the display device indicates that the value is 0 or not within the range. The collector may not be able to obtain the information correctly due to the wiring problem, please check whether the wiring is correct and firm;
3. If not for the above reasons, please contact the manufacturer.

Product Maintenance

1. It is not allowed to dismantle or loosen the filter cover, so as not to affect the measurement accuracy. Be especially careful when opening or closing the metal cap, as the filter cover is expensive and fragile.

The filter cover should be kept clean, often wipe with a soft cloth or fur;

2. Water should not enter the filter cover, and there should be no condensation in the cover. Always check whether the desiccant in the dryer becomes damp (from blue to red or white), otherwise it should be replaced in time or the desiccant should be dried in the oven to make it turn back to blue before use;
3. The TBQ total radiation sensor has good waterproof performance. Generally, it can not be covered for a short time or when the precipitation is small. However, if there is heavy rain (snow, ice, etc.) or rain for a long time, in order to protect the pyranometer, the observer should put a cover on it according to the specific situation, and open the cover after the rain stops;
4. The TBQ total radiation sensor has been used for more than two years, and its sensitivity must be re-calibrated by the manufacturer or the measurement department.

Service commitment

TBQ total radiation sensor from the date of delivery within 1 year due to quality problems caused by non-human factors, the production unit is responsible for free maintenance or replacement. If the user is artificially damaged, the cost will be charged, but the maintenance fee will not be charged. In addition, our company solemnly promises to be responsible for life-long maintenance of factory products.

Selection table

NBL-W-HPRS/Total radiation sensor V3.0
Changsha Zoko-Link Technology Co., Ltd.

No.	Power supply method	output signal	Explanation
NBL-W-HPRS			TBQ Total Radiation Sensor (Transmitter)
	5V-		5V Power supply
	12V-		12V Power supply
	24V-		24V Power supply
	Z-		No
		V	0-5V
		A1	4-20mA
		W2-	RS485
		V3-	0-20mV
For example: NBL-W-HPRS-12V-A1: TBQ total radiation sensor 12V power supply, 4-20mA current signal output			