

Welcome to use the ultrasonic weather meter manufactured by our company. For better use of the instrument, we recommend that you read through the product manual carefully before use.

Our company is in the process of continuous research and development, and we reserve the right to improve some features and designs without prior notice.

### Product Description

The micro meteorological 7-parameter sensor is a fully digital detection, high-precision sensor, which is integrated with an ultrasonic wind speed and direction sensor, a high-precision digital temperature, humidity, air pressure sensor, Pyrometer sensor, and piezoelectric rainfall sensor.

It can accurately and quickly detect wind speed, wind direction, atmospheric temperature, atmospheric humidity, atmospheric pressure, Pyrometer, and rainfall, and the built-in signal processing unit can output corresponding signals according to user needs.

The high-strength structural design can work reliably in harsh weather environments, with a small appearance and structure, high integration, light weight, and durability. It can be widely used in meteorology, environment, airports, ports, laboratories, industry and

agriculture, transportation and other fields.

### Operating principle

Measure the transit time of ultrasonic waves from N sensor to S sensor and compare with the transit time from S sensor to N sensor.

Similarly, compare the time from W to E with the time from E to W.

(N=North, S=South, E=East, W=West) For example: when the wind blows from the north, the time from N to S will be shorter than the time from S to N, and the time from W and E is the same as The transmission time from E to W is the same. By calculating the difference in transit time of ultrasonic waves between two points. The wind speed and direction of the wind can be calculated. This method of calculation has no relationship to other factors such as temperature.

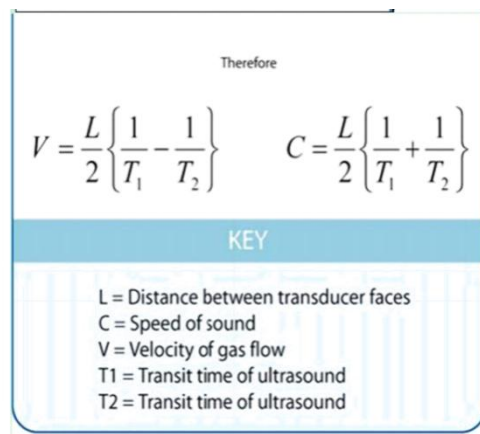
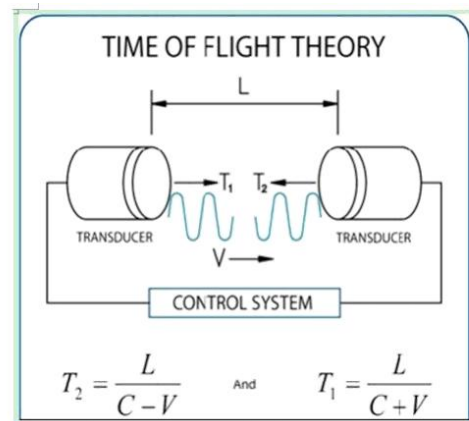

The piezoelectric rain sensor adopts piezoelectric ceramic kinetic energy rainfall monitoring, which can be identified according to the strength of raindrops falling and hitting. It can monitor from light rain to heavy rain, measure and calculate a single raindrop, and then

calculate the rainfall. Raindrops are affected by the weight of raindrops and air resistance during the falling process, and the speed when they reach the ground is a constant speed. According to  $P=mv$ , the weight of raindrops can be obtained by measuring the impact, and then the continuous rainfall can be obtained.

### Technical Parameters

<b>Voltage</b>		DC12-24V
<b>Signal Output</b>		RS485
<b>Communication</b>		MODBUS
<b>Baud rate</b>		9600bps
<b>Average power consumption</b>		0.35W
<b>Working temperature</b>		-20-50°C
<b>Working humidity</b>		0-95%RH
Standard length		2.5m
Material		ABS
IP Rate		IP65
Wind speed	Range	0-40m/s
	Accuracy	±0.5+2%FS
	Resolution	0.01m/s
Wind direction	Range	0-359°
	Accuracy	±3°
	Resolution	1°
Temperature	Range	-40-80°C
	Accuracy	±0.5°C
	Resolution	0.1°C
Humidity	Range	0-100%RH
	Accuracy	±5%RH
	Resolution	0.1%RH
Pressure	Range	10-1100hPa
	Accuracy	±1.5hPa
	Resolution	0.1hPa
Rainfall	Range	0~8mm/min
	Accuracy	±10%
	Resolution	0.01mm
Pyrometer	Range	0~1500W/m2
	Accuracy	±10%
	Resolution	1W/m2

(1) There is an 8-pin aviation plug at the bottom of the sensor, and its pins correspond to the pin definition: 1: Power + 2: 485 + 3: 485 - 4: GND

(2) If equipped with the collector produced by our company, directly use the sensor line to connect the sensor to the corresponding interface on the collector.

(3) If only the sensor is purchased separately, the line sequence of the supporting line of the sensor is as follows:

Line color	Output signals
	RS485
Red	+
Black	-
Yellow	RS485+
Blue	RS485-

**Note:** The marking on the wiring label on the communication cable shall prevail.

### Dimensions

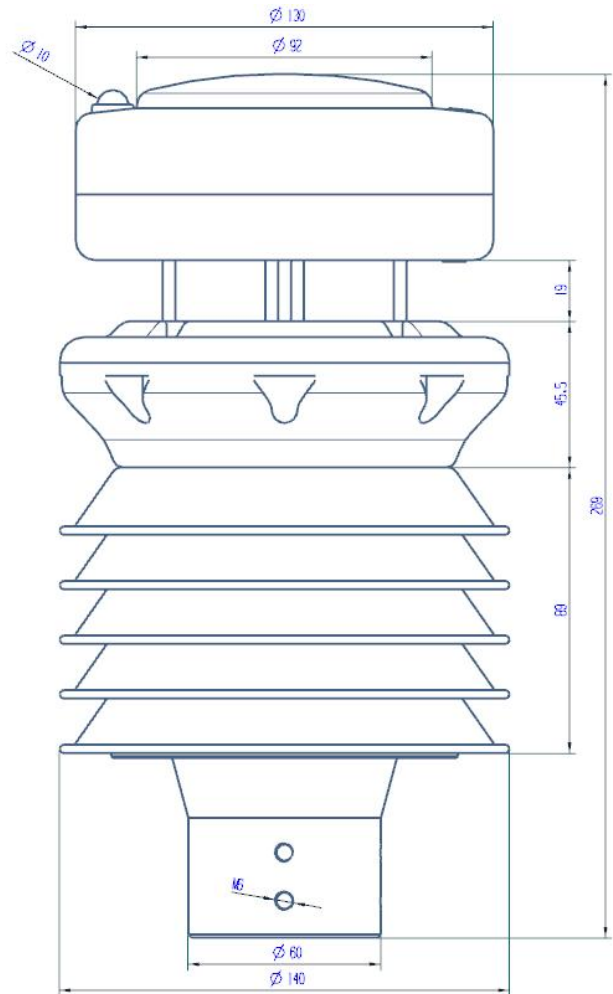

### Wiring method

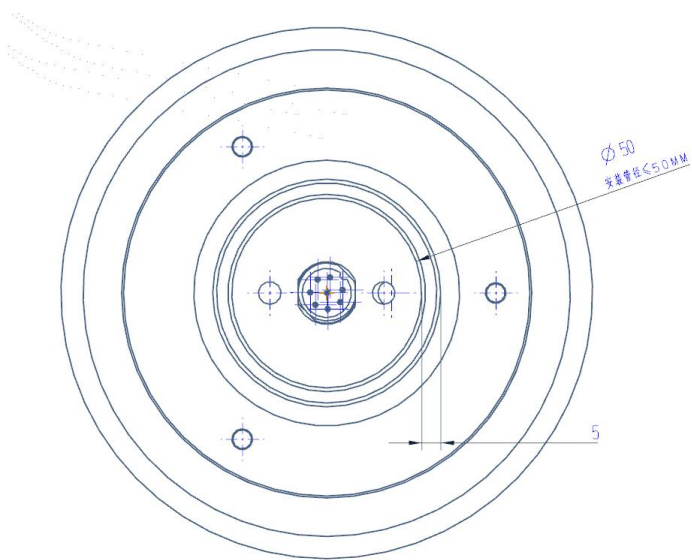

etc., which can affect the accuracy of the ultrasonic anemometer;

### The World Meteorological Organization recommends the following:

- Meteorological instrument installation standard: 10 meters above the ground in an open area; the definition of an open area is that the meteorological instrument is more than 10 meters above the height of any obstacle;
- If it is installed on a building, theoretically the installation height of the meteorological instrument should be 1.5 times the height of the building;
- If mounted on a boom on a mast, tower or branch of a mast, the length of the boom or branch must be twice the minimum diameter or diagonal of the tower. The boom needs to be installed on the side of the prevailing wind;

## Installation Precautions

The ultrasonic integrated sensor can meet multiple specifications and can be used in different environments in different places, without complicated maintenance and calibration on site.

- Check frequently to make sure the sensor is not being interfered with by other operating equipment which may not fully follow common standards, such as radio/radar transmitters, boat engines, motors, etc.;
- Do not install it on the same plane as any radar scanning device, and keep a distance of at least 2 meters;
- It is recommended to keep a distance from some radio receiving antennas around;
- The installation location should be far away from the vibration source;
- Use the cable recommended by our company;
- If the cable is not connected correctly after cutting, or the cable shielding wire is not connected correctly, there is no need to create a ground loop, just connect according to the installation instructions;
- Ensure the continuous power supply of the equipment during operation;
- Avoid the flocculation generated by surrounding buildings such as trees, utility poles, tall buildings,

## Installation method

The installation method is as follows:

**Positioning:** General equipment is installed on a vertical installation pipe to ensure measurement on the same horizontal plane;

**Alignment:** The detector should be fixedly installed with the pointing point pointing north.

Note: When installing, use a standard compass to determine the direction of the geographic North Pole, and it is ideal to keep the north direction of the instrument consistent with the direction of the compass;

**Installation:** The installation pipe needs 3 equidistant holes, tap M5 screws, the position is 7.5mm from the top of the pipe, and pass the cable through the installation pipe;

**NOTE:** The user must provide proper strain relief for the cables. Rotate the plug and apply light pressure to connect the plug to the plug on the device. When the plug is connected, turn the outer sleeve clockwise to lock the plug. The device can be fixed to the mounting



tube with 3 stainless steel screws. The customer must ensure that the equipment is installed in an open area, so as not to prevent the surrounding buildings from obstructing the airflow or causing flocculation. Do not install the equipment near radar or radio transmitters.

**After sales and service**

- The device has no moving parts and does not require complex routine maintenance on site.
- If the user opens the device by himself or damages the safety seal on it, he will no longer enjoy our quality guarantee.
- If there is any problem with the equipment, you can contact the company's staff to analyze and answer the problem;
- If the equipment needs to be returned, please carefully pack the instrument according to the original packaging and mail it to our company, and attach the detailed fault instructions of the instrument.

**MODBUS Communication Protocol**

Communication parameters: baud rate 9600, data bits 8 bits, no parity bit, and the interval between two communications is at least 1000ms

**【1】 Write device address**  
 Send: 00 10 Address CRC (5 bytes)  
 Return: 00 10 CRC (4 bytes)  
 Note: 1. The address bit of the read and write address command must be 00  
 2. Address is 1 byte, the range is 0-255  
 Example: Send 00 10 01 BD C0  
 Return: 00 10 00 7C

**【2】 Read device address**  
 Send: 00 20 CRC (4 bytes)  
 Return: 00 20 Address CRC (5 bytes)  
 Description: Address is 1 byte, the range is 0-255  
 Example: Send 00 20 00 68

Return: 00 20 01 A9 C0

**【3】 Read real-time data:**

If the device address is: 0x01,  
 Send: 01 03 00 00 00 00 0C CRC16

No.	Meaning	Offset	Bytes	Description
1	Device Address	0	1	Device Unique Address
2	Opcode (Read)	1	1	Fixed value 0x03
3	Register start number	2	2	First register number read
4	Read the number of registers	4	2	Number of elements to be read
5	CRC16 Check	6	2	Low Front High Back

**B. The device returns a data frame:**

The device returns:  
 01 03 18 xx xx ..... xx xx CRC16

No.	Meaning	Offset	Bytes	Description
1	Address field	0	1	Address(0x01)
2	Opcode	1	1	Read Only(0x03)
3	Data length field	2	1	Data Length
4	Data field	3	2	Wind speed
		5	2	Wind direction
		7	2	Temp
		9	2	Humidity
		11	2	Air pressure
		25	2	Pyrometer
4	Data field	21	2	Cumulative rainfall
		23	2	Real-time rainfall
5	Check field	27	2	

**Opcode:** It is fixed to 0x03, that is, read operation, and other operations are not supported.

**Starting number:** Range 0-15, indicating the first register number to read.

**Number of registers:** The range is 1-16, which means reading the last register number + 1. The read data does not include the register content of this number, and is only used as an end mark. Its value must be greater than or equal to the "start number".

**Data length:** It does not contain itself, but only indicates the number of bytes in the data field.

It is determined according to the "start number" and "number of registers" of the read instruction sequence.

Communication example (get 5 parameters):

Send: 01 03 00 00 00 05 CRC

Return: 01 03 0A 01 10 00 B0 00 FA 02 8A 27 AC CRC

01 10 is the wind speed data, which is a hexadecimal integer, converted to decimal is 272, and the wind speed resolution is 0.01, which is 2.72m/s

00 B0 is the wind direction data, which is a hexadecimal integer, converted to decimal is 176, and the wind direction resolution is 1, that is, the wind direction is 176 degrees.

00 FA is temperature data, which is a hexadecimal integer, converted to decimal is 250, and the temperature resolution is 0.1, which is 25.0°C; The temperature has negative numbers, and the returned negative numbers are expressed in the form of hexadecimal complement. For example, the temperature is -155 converted from FF 65 to decimal, and the temperature resolution is 0.1, which is -15.5°C.

02 8A is the humidity data, which is a hexadecimal integer, converted to decimal is 650, and the humidity resolution is 0.1, which is 65.0%RH.

27 AC is air pressure, which is a hexadecimal integer, converted to decimal is 10156, and the resolution of the air pressure sensor is 0.1, which is 1015.6hPa.

**【4】 Cumulative rainfall zeroing**

Send→Address 06 00 08 00 00 CRC

Return ←Address 06 00 08 00 00 CRC

**C. Calculation of CRC16 check code**

- 1) Preset a 16-bit register as hexadecimal FFFF (all 1); this register is called the CRC register;

- 2) XOR the first 8-bit binary data(the first byte of the communication information frame) with the lower 8 bits of the 16-bit CRC register, and put the result in the CRC register;
- 3) Shift the content of the CRC register to the right by one bit (towards the lower bit), fill the highest bit with 0, and check the shifted out bit after the right shift;
- 4) 4) If the shifted bit is 0: repeat step 3 (shift right again);  
If the shifted out bit is 1: XOR the CRC register with the polynomial A001 (1010 0000 0000 0001);
- 5) Repeat steps 3 and 4 until the right shift is 8 times, so that the entire 8-bit data is processed;
- 6) Repeat steps 2 to 5 to process the next byte of the communication information frame;
- 7) After all the bytes of the communication information frame are calculated according to the above steps, the high and low bytes of the obtained 16-bit CRC register are exchanged;
- 8) The finally obtained CRC register content is the CRC16 code. (Note: The obtained CRC code is in the order of low first and high last)

**D. Channel data conversion**

For example 1: the temperature hexadecimal code is "00 C3", converted into binary is "0000000 11000011". The first binary bit is "0", so its value is a positive number. At this time, the decimal value "195" can be converted by the method in "1". Finally multiply it by 0.1 to get the final result "19.5".

For example 2: The temperature hexadecimal code is "FF 3D", converted into binary is "11111111 00111101", the first bit of the binary is "1", so its value is negative.

The specific conversion steps are as follows:

- (1) Replace the first bit of its binary with "0" to get: "01111111 00111101"
- (2) After inverting the last 15 digits, get: "00000000 11000010"
- (3) Add "1" to get: "00000000 11000011"
- (4) According to the positive number representation





method in 1, the decimal value "**195**" is obtained  
 (5)Because it is a negative value, the result is "**-195**"  
 (6)The result is divided by 10 and the final result is "-19.5"

So: **00 C3** → **19.5°C**  
**FF 3D** → **-19.5°C**

11	Large trees can be blown down, and general buildings are severely damaged	28.5~32.6
12	There are few on land, and its destructing power is extremely large	>32.6

**Attached table: wind speed rating table**

Rate	Characteristics of terrestrial objects	Wind speed (m/s)
0	The smoke goes straight up	0~0.2
1	The smoke can indicate the direction of the wind, and the leaves sway slightly	0.3~1.5
2	The human face feels the wind, and the leaves move slightly	1.6~3.3
3	Leaves and twigs swayed, flags spread, tall grass swayed	3.4~5.4
4	Can blow dust and paper from the ground, shake branches, and undulate tall grass	5.5~7.9
5	Small leafy trees sway, inland water surface has small waves, tall grass has distinct undulating waves	8.0~10.7
6	The big branches are shaking, the wires are whistling by the wind, it is difficult to hold an umbrella, and the tall grass falls to the ground from time to time	10.8~13.8
7	The whole tree shakes, the big branches bend down, and it is inconvenient to walk in the wind	13.9~17.1
8	Small branches can be broken, and people feel great resistance when moving against the wind	17.2~20.7
9	The thatched house is damaged, the roof tiles are lifted, and the big branches can be broken.	20.8~24.4
10	Trees can be blown down and buildings in general damaged	24.5~28.4

**Contact US**

Company: Changsha Zoko Link Technology Co., Ltd.

Contact: +8618073152920

Zip code: 421000

Email: sales@niubol.com

Website: <http://www.niubol.com>

Address: Room 103, Area D, Houhu Industrial Park, Yuelu District, Changsha City, Hunan Province, china